

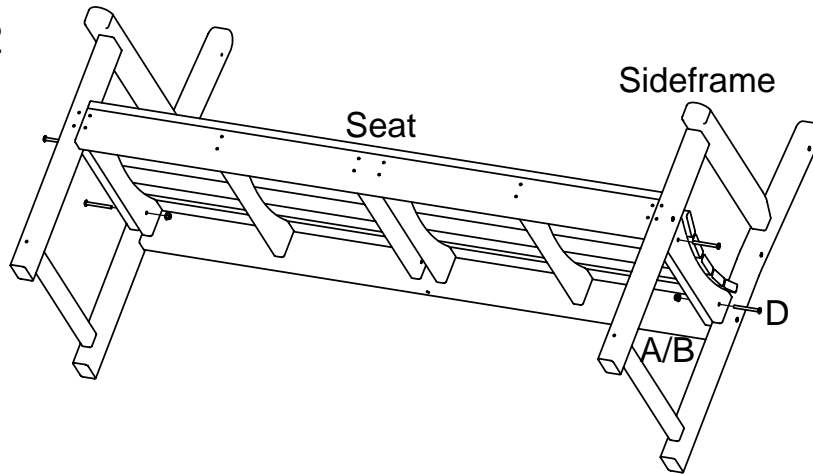

**Assembly Instructions**  
**Model: GB60, GB72**

**Step 1**  
 Attach the seat to the sideframes using (4) 2½" bolts with washers and nuts  
 \*Do not tighten until final step\*



- (1) Seat
- (1) Back
- (2) Sideframes
- (1) Center leg
- (1) Hardware pack

**Step 2**  
 Attach the back and seat to the sideframes using (8) 10x3 screws

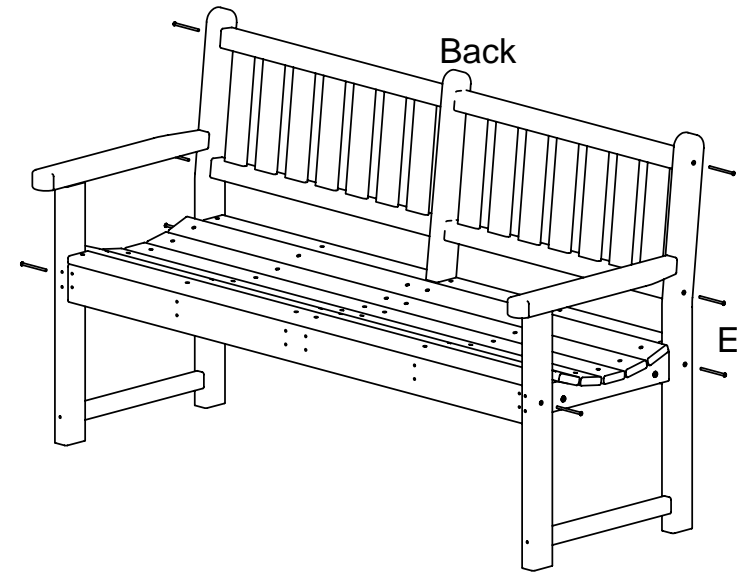

**Step 3**  
 Secure the back using (1) 5" Lag with washer

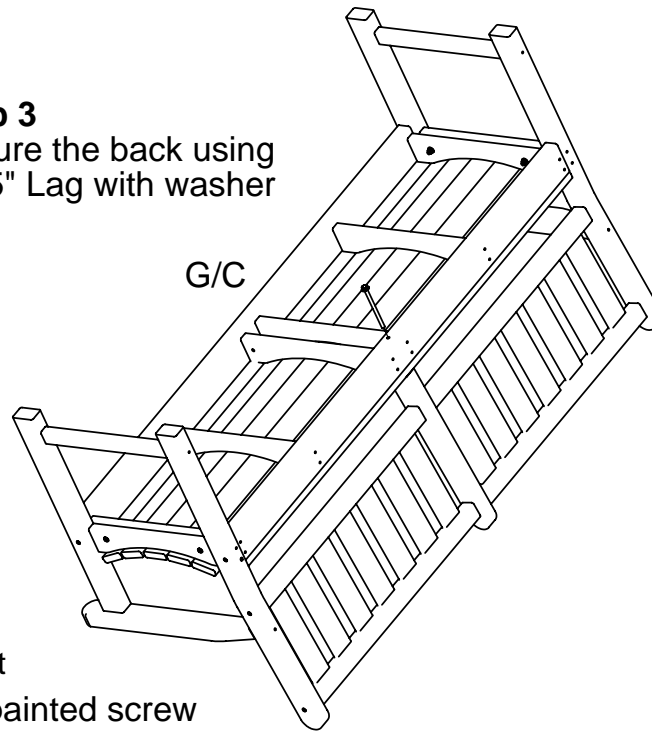

**TOOLS NEEDED**

- 7/16 & 1/2" wrench
- Phillips head screwdriver
- 5/32" hex key

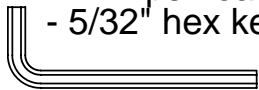

**Step 4**  
 Attach the center legs to the seat using (2) 3" Lags with washers  
 \*Tighten all fasteners at this time\*

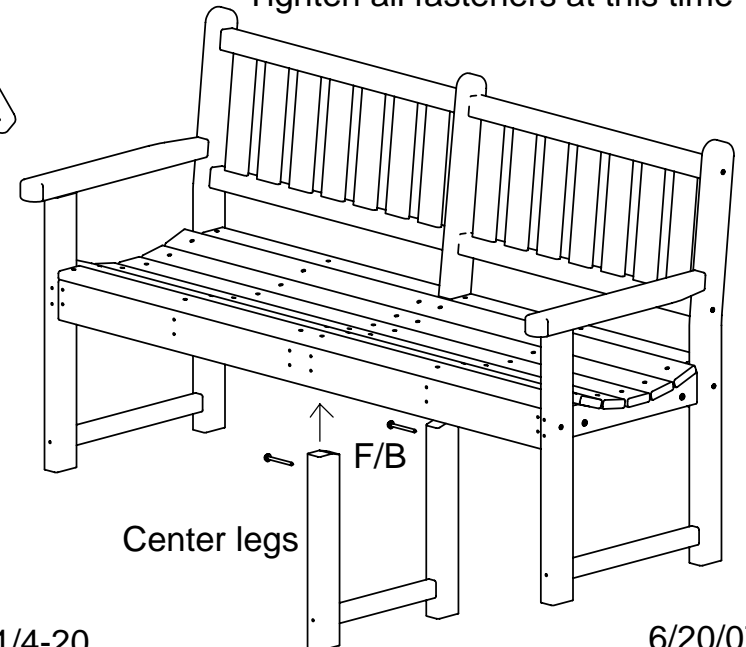

Qty.	Description
4	A - 1/4" lock nut
6	B - 1/4" washer
1	C - 5/16" washer
4	D - 2½" bolt
8	E - 10x3" painted screw
2	F - 1/4x3" Lag
1	G - 5/16x5" Lag

All bolts are 1/4-20

6/20/07