

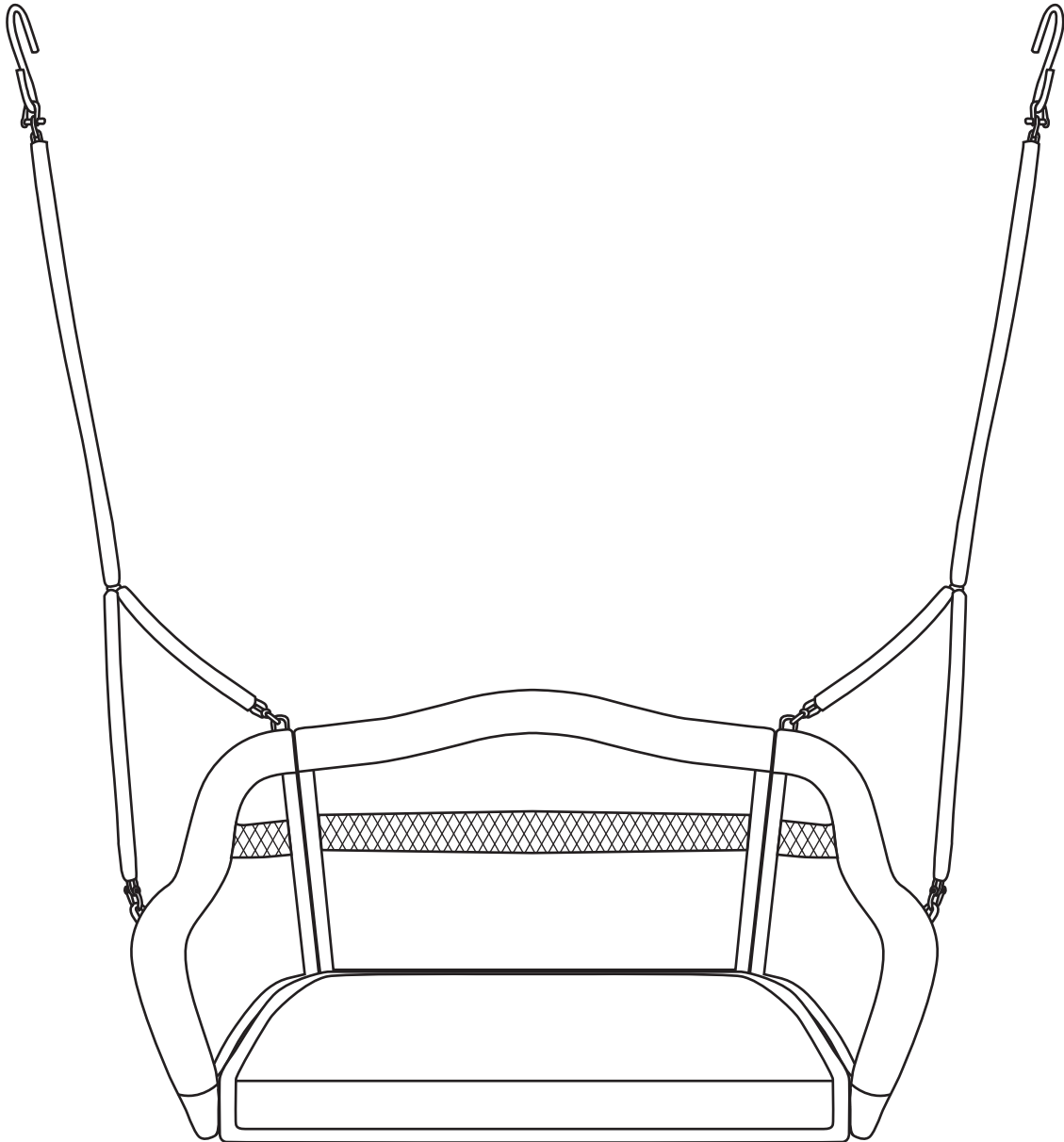

Assembly Instruction

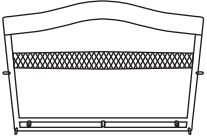



Resin Wicker Swing

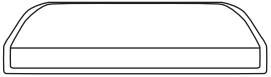
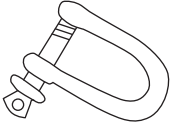
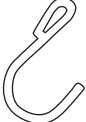
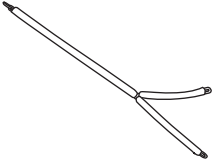

PARTS LIST:

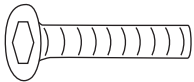
<p>(A) Back Qty: 1</p> 	<p>(B) Right Side Qty: 1</p> 	<p>(C) Left Side Qty: 1</p> 
<p>(D) Seat Qty: 1</p> 	<p>(E) Ring Lock Qty: 6</p> 	<p>(F) Metal Arm Qty: 2</p> 
<p>(G) Chain Qty: 2</p> 		

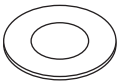
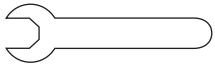
HARDWARE LIST:

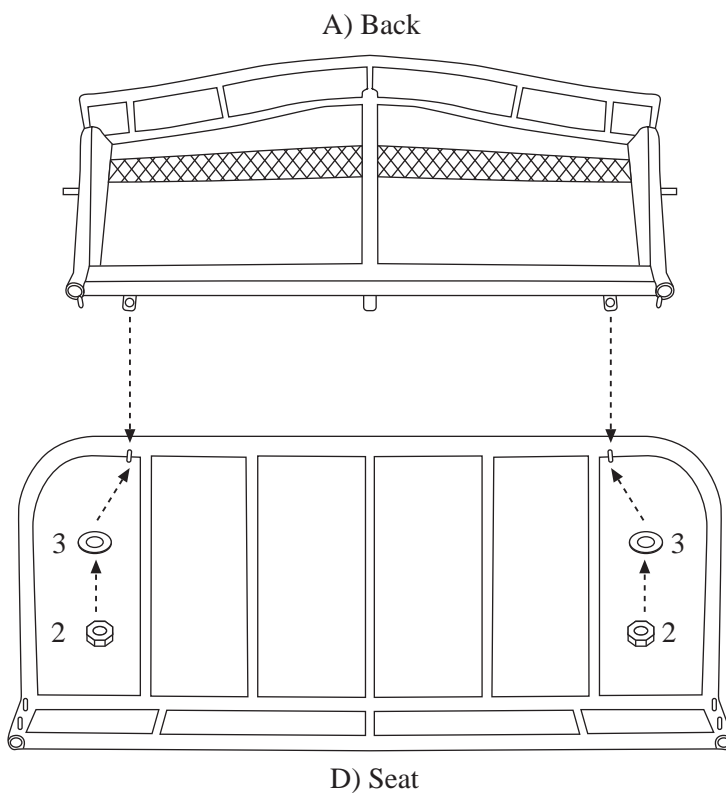

<p>1. Bolt Qty: 2</p> 	<p>2. Nut Qty: 8</p> 	<p>3. Washer Qty: 8</p> 
<p>4. Single-end Wrench Qty: 1</p> 	<p>5. Hex Wrench Qty: 1</p> 	

Step 1 Note: Wait to fully tighten the Nuts and Bolts until they have all been inserted in the last step. Two people might be required to align holes for fasteners.



Item	Drawing	Qty
2		2
3		2

Step 2

Item	Drawing	Qty
1		1
2		2
3		2

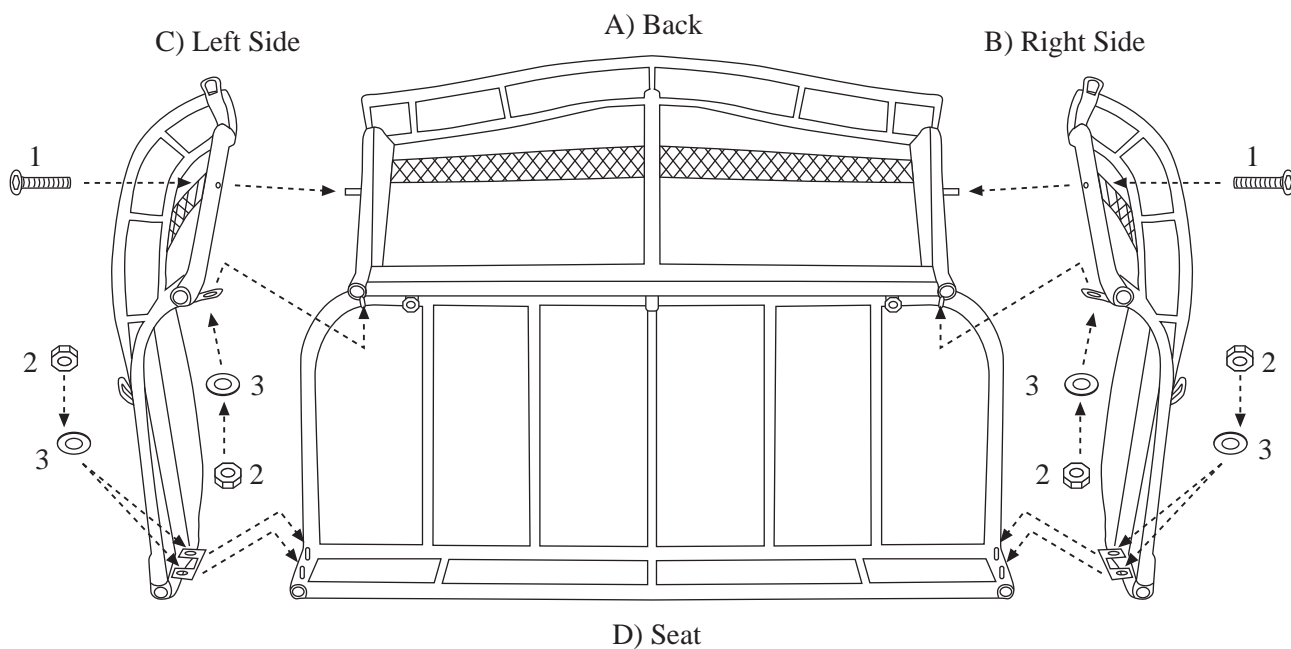

Step 3

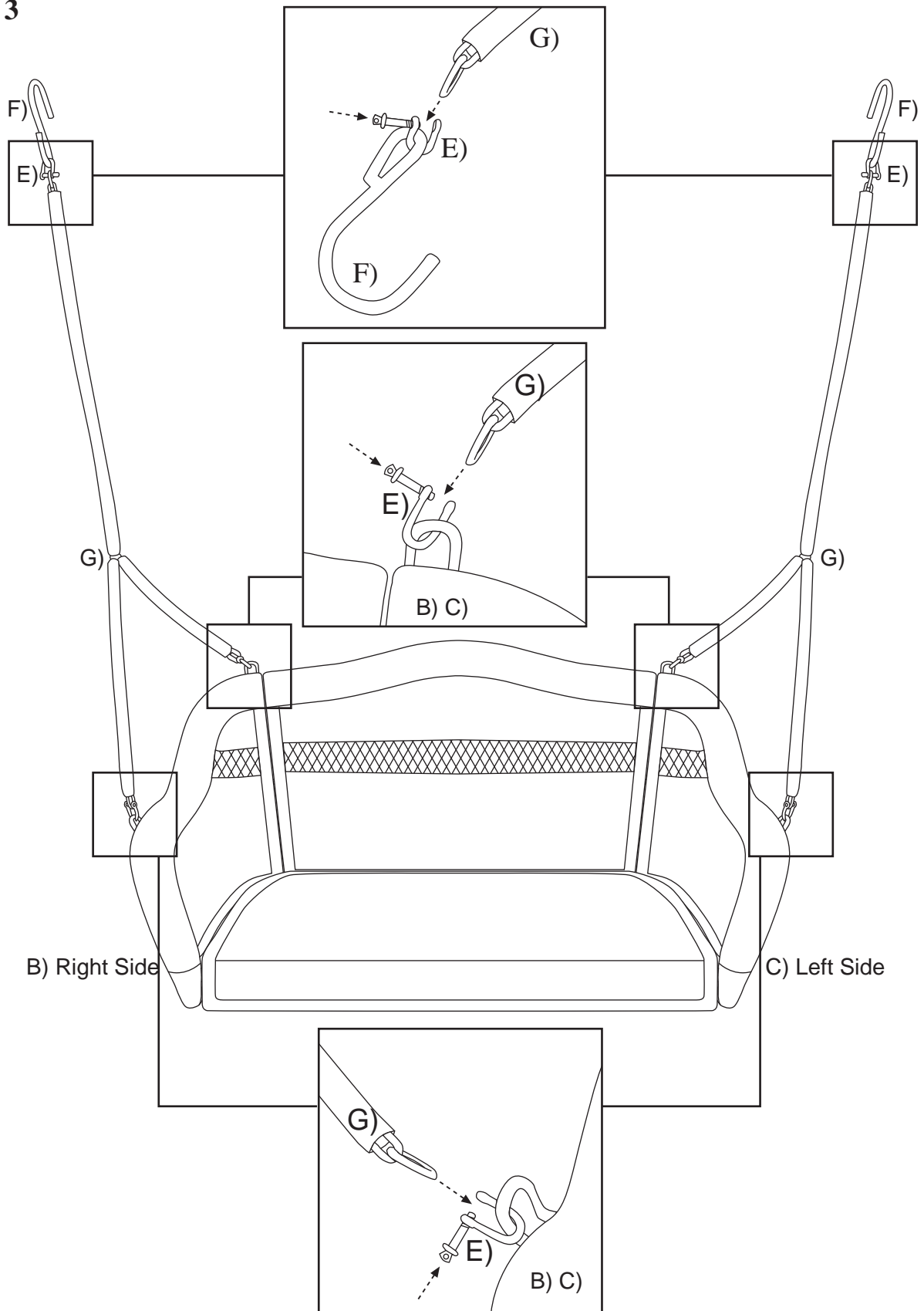

*On assembly a rubber mallet or hammer is needed or 2 person assembly is required to squeeze the right and left arms together and fit into the brackets to tighten the nuts and washers together. This should be put in the instructions for assembly. Also is recommended not to tighten nuts all the way to make assembly easier until everything is fully assembled together.

** BE SURE ALL FASTENERS ARE FULLY TIGHTENED BEFORE SITTING ON THE ITEM.